

*High²ⁱⁿ¹
Chair*



Bubbles

Item Code: BUE1008

MADE IN TAIWAN

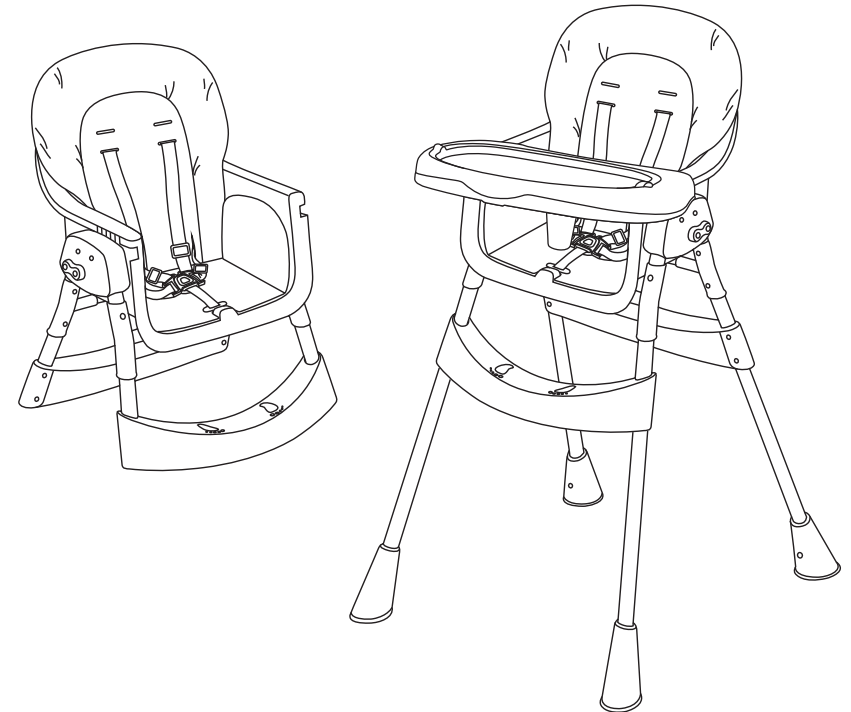

**IMPORTANT!
READ CAREFULLY AND KEEP
FOR FUTURE REFERENCE**

This high chair complies with:
EN14988:2017
ASTM F404
AS4684:2009
Suitable for child weighing
under 15 kg (6-36 months).

WARNINGS

- Never leave the child unattended.
- Always use the restraint system and ensure it is correctly fitted.
- Falling hazard: prevent your child from climbing on the product.
- Do not use the product unless all components are correctly fitted and adjusted.
- Be aware of the risk of open fires and other sources of strong heat in the vicinity of the product.
- Be aware of the risk of tilting when your child can push its feet against a table or any other structure.
- Statement not to use the product until the child can sit up unaided.
- Statement not to use the product if any part is broken, torn or missing.
- Keep children away when unfolding and folding the product to avoid injury.
- This product is intended for children able to sit up unaided (minimum 6 months) and up to 3 years or a maximum weight of 15 kg.

USE

5 How to fasten the harness

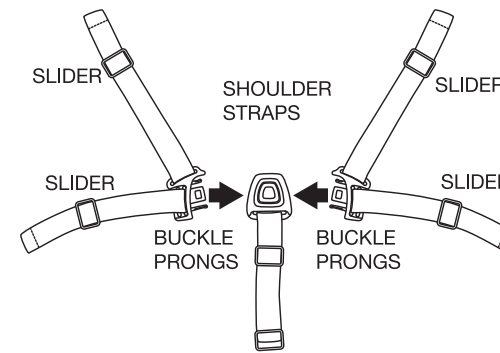

 **WARNINGS**
Use this harness
at all times.

6 How to adjust the tightness (To tighten up)

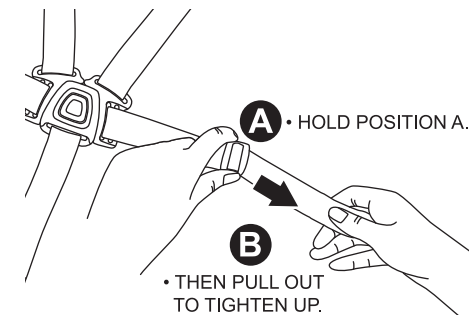

7 How to adjust the tightness (To loosen)

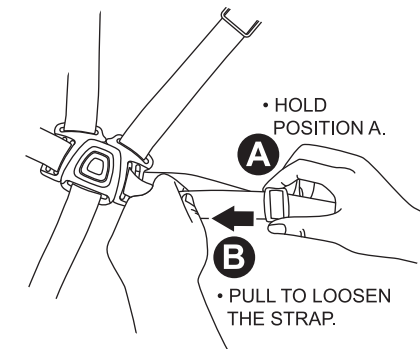

USE

3 To unfold the high chair.

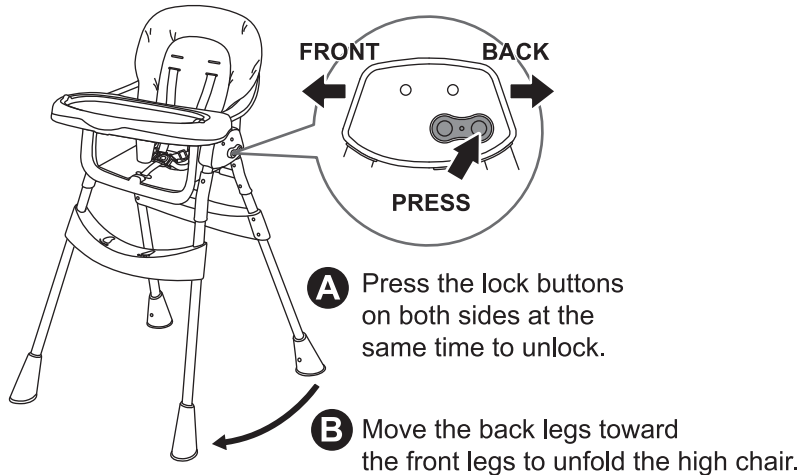

4 Meal tray storage

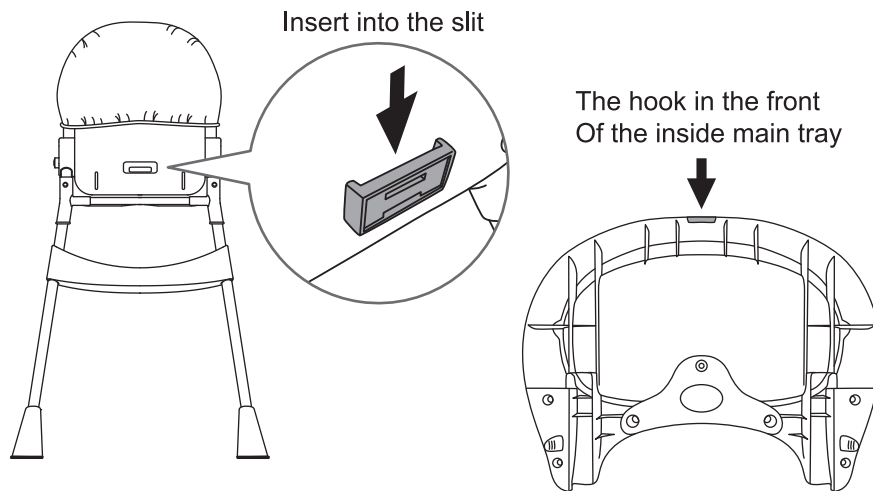

⚠️ WARNINGS

- FALL HAZARD:** Children have suffered severe head injuries including skull fractures when falling from high chairs. Falls can happen suddenly if child is not restrained properly.
- Always use restraints, and adjust to fit snugly.
 - Tray is not designed to hold child in chair.
 - Stay near and watch child during use.
 - The child should be secured in the high chair at all times by the restraining system.
 - The tray is not designed to hold the child in the chair.
 - It is recommended that the high chair be used only by children capable of sitting upright unassisted or weighs more than 20 lb (9.1kg).
 - The child should be secured in the high chair at all times by the restraining system, either in the reclining or upright position.
 - The tray is not designed to hold the child in the chair.
 - It is recommended that the high chair be used in the upright position only by children capable of sitting upright unassisted.

⚠️ WARNINGS

- Follow the manufacturer's instructions.
- Do not leave children unattended.
- The harness must always be used and correctly fitted—most injuries from high chairs are caused by falls.
- Position the high chair away from solid structures and benches to avoid injuries caused by falls and by access to dangerous items.
- Advice to use the high chair on a flat, even and horizontal floor and not to elevate the high chair on any structure or table.
- To reduce the risk of injury, advice shall be provided to position the high chair away from furniture, walls, hot surfaces and liquids, window covering cords, and electrical cords and position the high chair away from furniture when the chair is not being used at a table with a tray removed.
- Advice that the high chair should only be used in an upright position once the child is capable of reliably and consistently sitting upright.
- Advice on regular inspection and maintenance.
- Advice not to use the high chair if it is not working correctly and that the owner should seek repair.

USE

1 3 positions for meal tray adjustment.

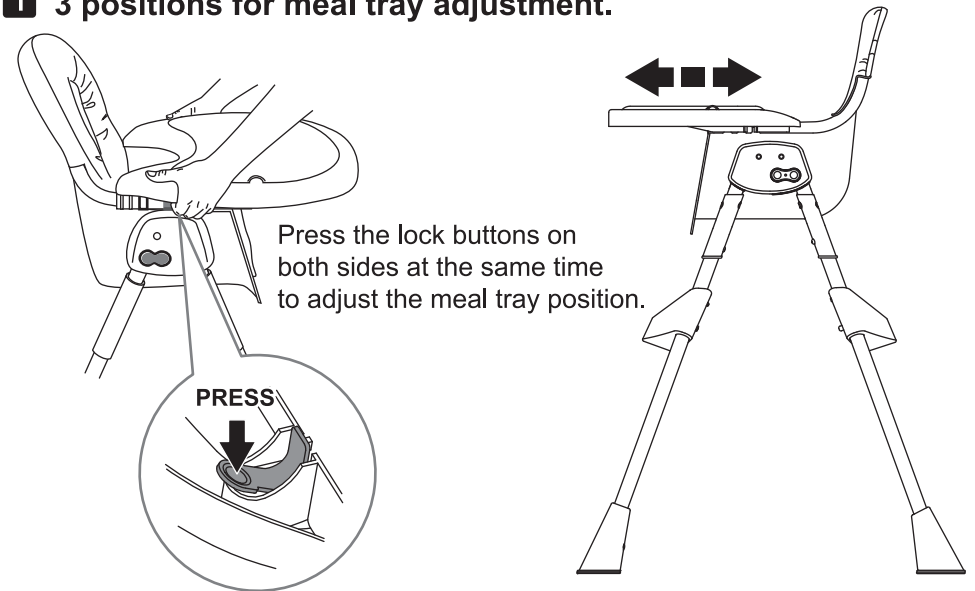

2 Short dining chair

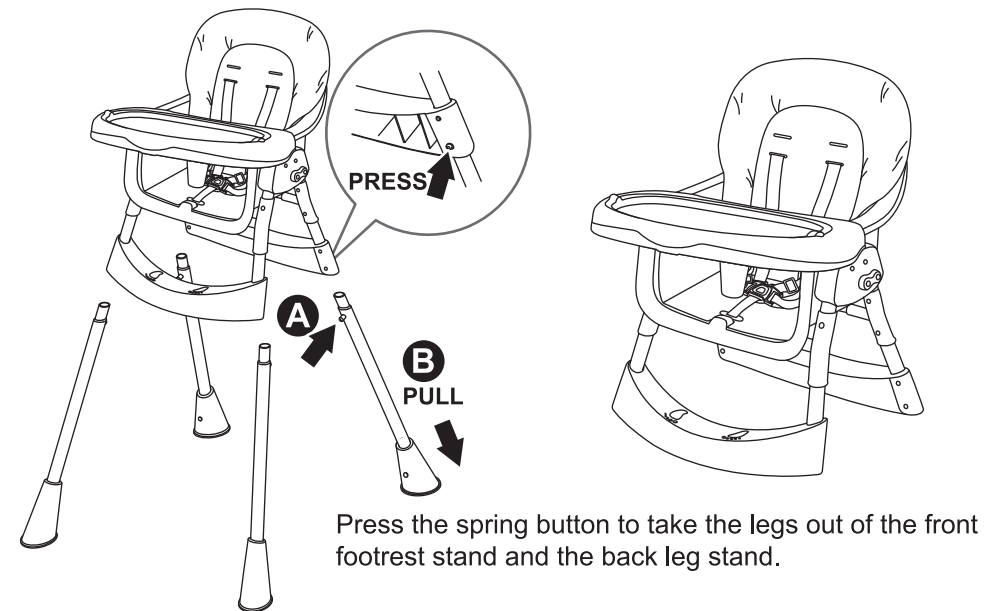

INSTRUCTION

3 To assemble the legs.

Insert the legs into the holes below the front footrest stand and the back leg stand.

The right and left sides of the plastic parts should be correspondent.

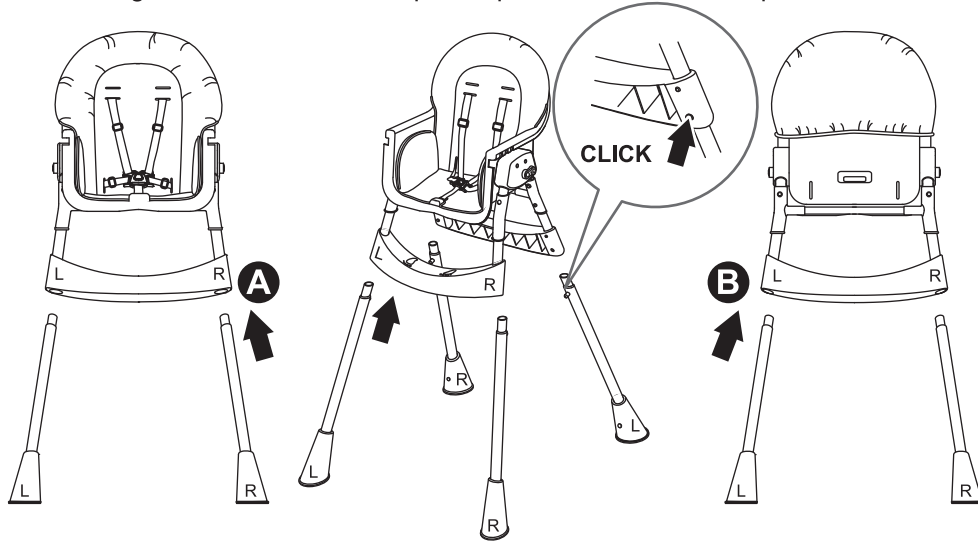

4 Assemble the meal tray set onto the seat assembly.

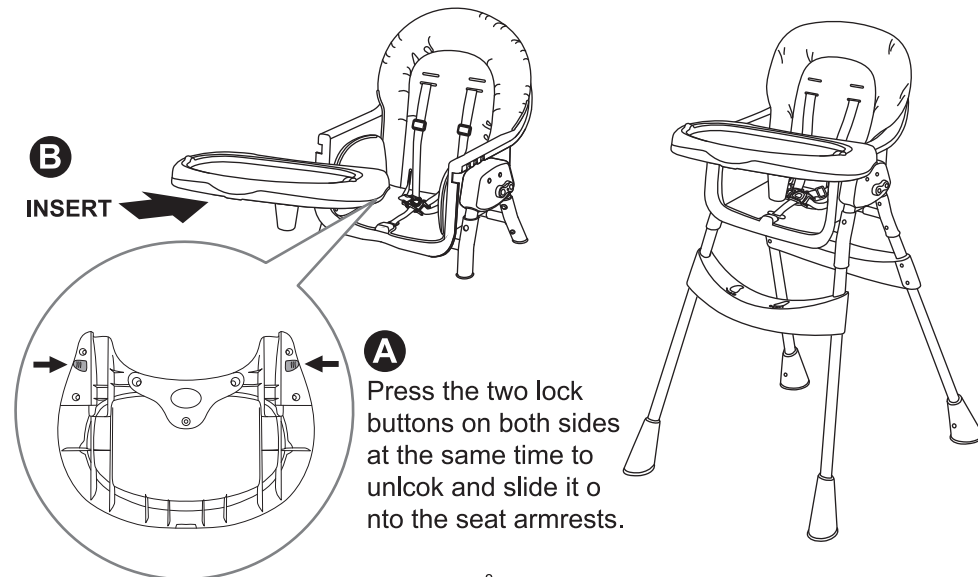

! WARNINGS

- Prevent serious injury or death from falls or sliding out.
- Never leave your child unattended, direct adult supervision is required at all times.
- Do not use accessories or replacement parts other than those approved by the manufacturer.
- Check your high chair for loose screws, worn parts, torn material or stitching on a regular basis. Replace or repair parts as needed.
- Never allow your high chair to be used as a toy.
- Always use on a flat and level floor.

CLEANING AND MAINTENANCE

- The tray can be washed under running water with mild cleaning agents, preferably liquids. avoid soiling the strap buckle to ensure its unfailling operation. If the buckle gets dirty, it can be soaked and rinsed in warm water.
- To prolong the life of your high chair keep it clean and do not leave it in the direct sunlight for extended periods of time.
- To clean use only mild household soap or detergent and warm water on a sponge or clean cloth.

PARTS LIST

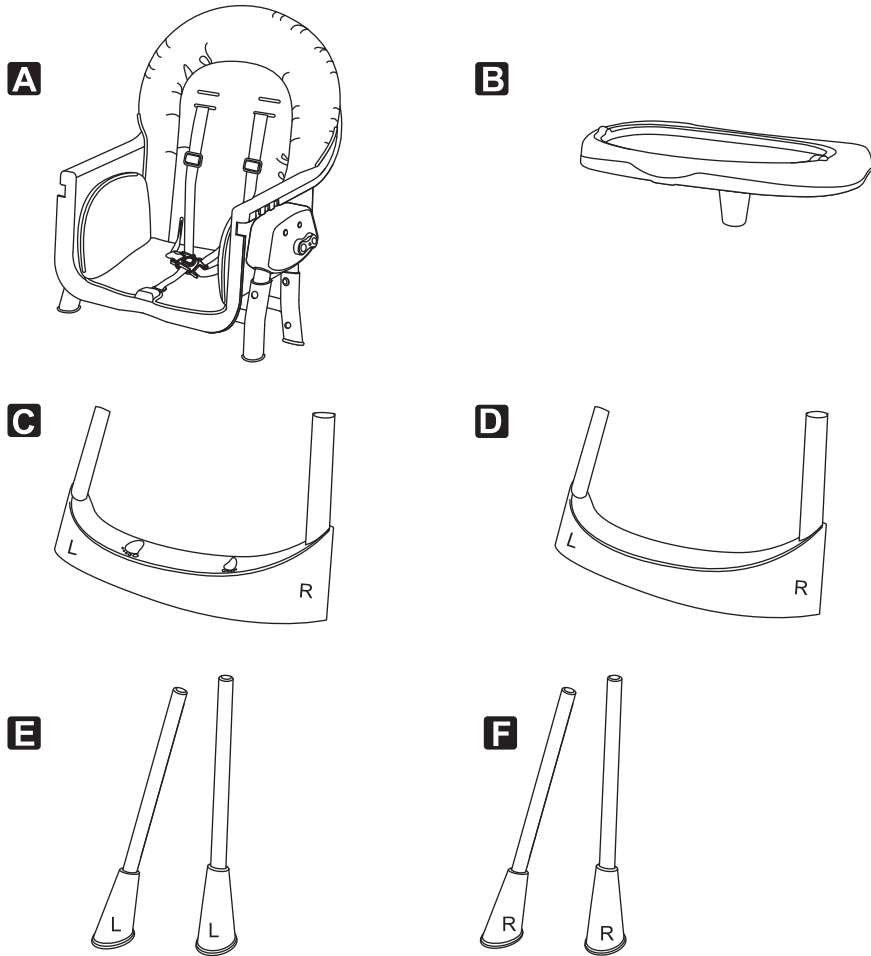

A 1 x Seat Assembly

B 1 x Base tray
1 x Removable tray

C 1 x Footrest stand (Front)
(Front Footrest stand is marked with "Footprint".)

D 1 x Leg Stand (Back)

E 2 x Legs(L)

F 2 x Legs(R)

INSTRUCTION

1 To unfold the frame.

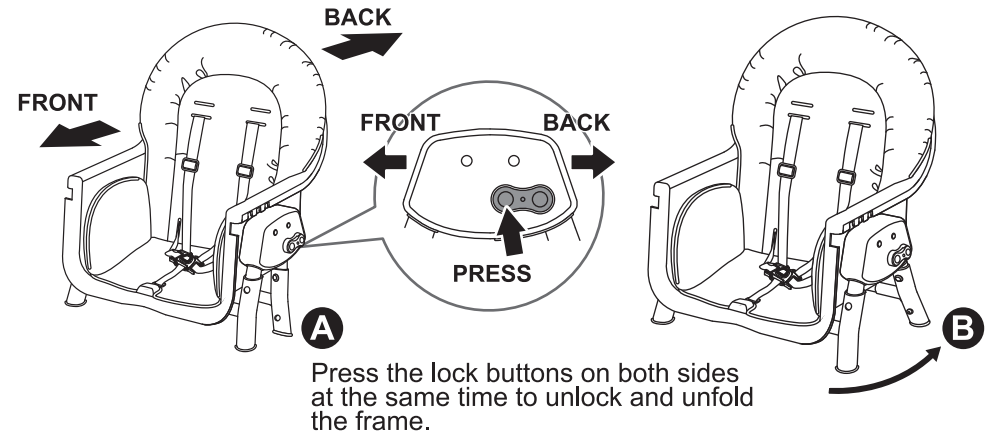

Press the lock buttons on both sides at the same time to unlock and unfold the frame.

2 To assemble the frame.

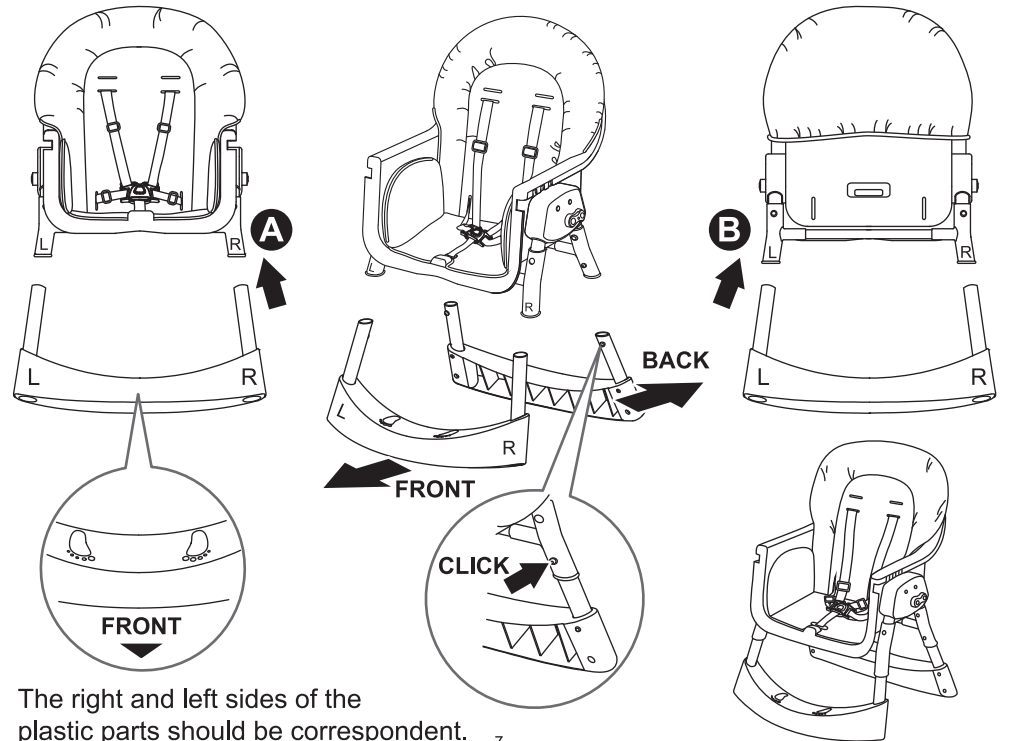

The right and left sides of the plastic parts should be correspondent.